



**California
Subject
Examinations for
Teachers®**

TEST GUIDE

**HOME ECONOMICS
SUBTEST II**

**Sample Questions and Responses
and Scoring Information**

Copyright © 2005 by National Evaluation Systems, Inc. (NES®)

"California Subject Examinations for Teachers," "CSET," and the "CSET" logo are registered trademarks of the California Commission on Teacher Credentialing and National Evaluation Systems, Inc. (NES®).

"NES®" and its logo are registered trademarks of National Evaluation Systems, Inc.™

CS-TG-QR182X-01

Sample Test Questions for CSET: Home Economics Subtest II

Below is a set of multiple-choice questions and constructed-response questions that are similar to the questions you will see on Subtest II of CSET: Home Economics. You are encouraged to respond to the questions without looking at the responses provided in the next section. Record your responses on a sheet of paper and compare them with the provided responses.

1. Which of the following nutrients are used in the body to repair tissues, form antibodies, and help control fluid balance?
 - A. proteins
 - B. vitamins
 - C. carbohydrates
 - D. fats

2. Rapid assays are used within the food industry to:
 - A. kill harmful bacteria on the surface of food.
 - B. delay the spoilage of produce by creating mold-resistant products.
 - C. prevent harmful bacteria from infecting livestock.
 - D. identify pathogens in various food products.

3. Which of the following statements best defines the "Use-By" date found on many food products?
 - A. the last date the food product is at peak quality
 - B. the date on which the food product must be removed from sale
 - C. the last day the food product is safe for consumption
 - D. the day of the food product's final processing or packaging

4. The order in which ingredients appear on a food label is an indication of which of the following?
 - A. the relative amounts of each ingredient in the product
 - B. the order in which the ingredients were added to the product
 - C. the comparative nutritional value of each ingredient in the product
 - D. the prevalence of the flavor of each ingredient in the product

5. Use the menu below to answer the question that follows.

Breakfast	instant oatmeal orange juice
Mid-morning snack	apple graham crackers milk
Lunch	veggie burger cranberry juice
Late afternoon snack	peanut butter and carrots milk
Dinner	chicken Spanish rice green beans milk
Evening snack	popcorn

This is a typical daily menu for Shula, a woman in her early twenties. She has been trying to lose weight through diet modification and exercise for several months, but she has had little success. According to national dietary guidelines, which of the following should Shula consider doing first in order to lose weight?

- A. limiting the amount of carbohydrates in her diet
- B. evaluating her portion sizes
- C. decreasing her consumption of dairy products
- D. eliminating snacks from her diet
6. Symptoms of lactose intolerance often include:
- A. headaches and blurred vision.
- B. bloating, cramps, and diarrhea.
- C. sneezing, runny nose, and rash.
- D. anxiety and mood swings.
7. A diet that is high in fruits, vegetables, and grains, low in red meat and dairy products, and moderate in fish, poultry, and wine is typical of which of the following regions?
- A. northern Europe
- B. North America
- C. southern Europe
- D. Central America
8. The California Office of Environmental Health Hazard Assessment (OEHHA) has warned that children and women of childbearing age should reduce their consumption of certain species of fish in order to limit their exposure to:
- A. PCBs (polychlorinated biphenyls).
- B. lead.
- C. methylmercury.
- D. *E. coli* bacteria.

9. Jim has a motion impairment that requires him to use a wheelchair for mobility. Which of the following layouts, if designed with accessible counters, shelves, and appliances, would offer him the most accessibility within a kitchen?

A.

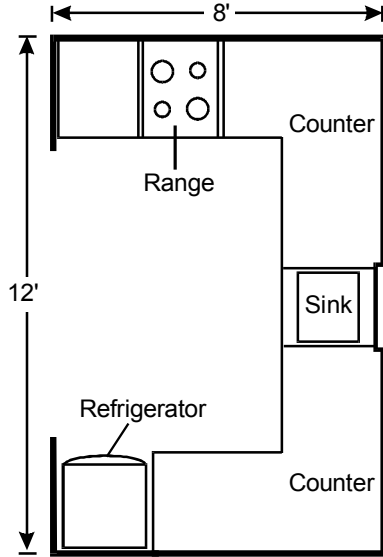

B.

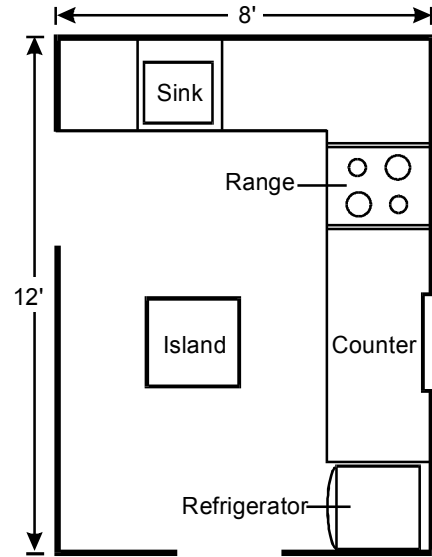

C.

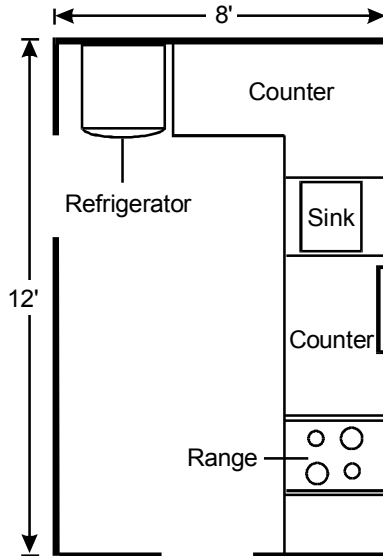

D.

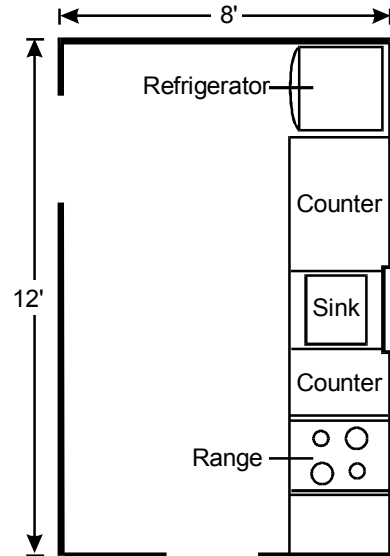

10. A two-quart shallow saucepan would be most appropriate to use for which of the following tasks?
- A. reducing a gravy
 - B. sautéing vegetables
 - C. simmering a pot roast
 - D. scrambling eggs
11. Second-degree burns received from cooking should be treated immediately by:
- A. applying butter or margarine to the affected area.
 - B. placing the affected area under cold water for several minutes.
 - C. covering the affected area with a clean bandage.
 - D. soaking the affected area in warm water and vinegar.
12. The primary purpose of the California Uniform Retail Food Facilities Law is to provide uniform statewide standards regarding:
- A. cooking and other food preparation skills for licensed chefs and other employees who prepare food for the public.
 - B. marketing, display, and pricing of food in retail outlets such as supermarkets and convenience stores.
 - C. sanitation and quality control in facilities such as flour mills and meat-processing plants that process food products.
 - D. health and sanitation in restaurants and other facilities that prepare and serve food to the public.

13. Which of the following should be the main goal for selecting a vegetable dish to accompany a meal?
- A. to introduce a variety of shapes and sizes to the meal
 - B. to provide colors and textures that contrast with the main course
 - C. to complement or favorably contrast the flavors of the main course
 - D. to provide a consistent temperature among all components of the meal
14. A recipe for bread calls for one cup of flour. Which of the following is the most accurate procedure for using a one-cup dry measure to measure the flour?
- A. Press the flour firmly to eliminate air spaces, then add and pack flour until it is level with the top.
 - B. Scoop the flour from the container, then add flour until it is rounded above the rim of the cup.
 - C. Spoon the flour gently into the cup until it is overfilled, then use a straightedge to level the flour.
 - D. Fill the cup by scooping flour from the bag, then shake the cup until the flour is level.
15. Culinary school training followed by an apprenticeship is the most appropriate training path for which of the following careers?
- A. department manager at a supermarket
 - B. food product developer in industry
 - C. food buyer at a university
 - D. head chef at a restaurant

16. Use the information below to complete the assignment that follows.

Mr. Jenkins is a man in his mid-seventies. He maintains a traditional American diet that is high in red meat and potatoes and low in fruits and vegetables. He walks for 30-minute intervals several times a week with his friends. Although he is currently in good health, he is concerned that his present diet may not be appropriate for this stage of his life cycle.

Using your knowledge of food and nutritional science, write a response in which you:

- discuss two nutritional issues that may be important for maintaining good health in this individual, given the information presented above; and
- identify two dietary modifications that this individual should make to address these nutritional issues.

17. Use the information below to complete the assignment that follows.

Khadija and Alice are preparing a brunch for some of their friends. Their proposed menu for the gathering is given below.

Scrambled eggs Pancakes French toast Hash browns Ham Sausage patties Wheat toast Condiments: butter, maple syrup, jam, salt and pepper Beverages: coffee, tea, and orange juice

Using your knowledge of meal planning, write a response in which you:

- evaluate this menu in terms of nutritional content and aesthetic balance;
- suggest one substitution or modification that would improve the nutritional content of this menu, and one that would improve its aesthetic balance; and
- discuss two food safety issues that should also be considered in the preparation and presentation of this menu.

Sample Written Response Sheets for CSET: Home Economics Subtest II

For questions 16 and 17, examinees would record their written response to each question on a one-page response sheet located in their answer document. The length of their response to each question is limited to the lined space available on the response sheet. A sample of the response sheet is provided below.

Seat 00701 Site 436B ATA 007 PM Form # 105 CS 07/17/2004	ID# : 4-024-755-4 DO NOT WRITE IN THIS BOX <input type="checkbox"/> <input type="checkbox"/>	Assignment 1 Response Sheet
---	---	--

DIRECTIONS
The directions and assignment are presented in your test booklet. Read them carefully before you begin to write. The lined page(s) of this response sheet are the only page(s) that will be scored for this assignment. RESPONSES WRITTEN IN THE TEST BOOKLET OR ANYWHERE ELSE IN THIS DOCUMENT WILL NOT BE SCORED. DO NOT WRITE YOUR NAME ANYWHERE IN THIS SECTION.

DO NOT WRITE OUTSIDE THESE MARGINS

DO NOT WRITE OUTSIDE THESE MARGINS

DO NOT WRITE OUTSIDE THESE MARGINS

40247554105G001





DO NOT WRITE OUTSIDE THESE MARGINS

DO NOT WRITE OUTSIDE THESE MARGINS

DO NOT WRITE OUTSIDE THESE MARGINS

G PAGE 3

STOP. END OF ASSIGNMENT 1.



Annotated Responses to Sample Multiple-Choice Questions for CSET: Home Economics Subtest II

Nutrition, Foods, and Hospitality

1. **Correct Response: A.** (SMR Code: 2.1) Proteins are one of the major nutrients the human body needs to function. The protein collagen accounts for one third of all of the protein in the human body and plays a major role in tissue repair. Proteins form antibodies, which are important in the body's immune response. Large protein molecules in blood plasma help regulate the balance of fluids and electrolytes in the body.
2. **Correct Response: D.** (SMR Code: 2.1) Rapid assays are diagnostic tests used within the food industry to investigate the safety of food products for consumption. These tests help inspectors quickly identify contaminants such as certain kinds of bacteria and other organisms that may be dangerous to consumer health.
3. **Correct Response: A.** (SMR Code: 2.1) According to the Food Safety and Inspection Service of the U.S. Department of Agriculture, the "Use-By" date indicates the last date the product is considered to be at peak quality. This product dating system is commonly used on goods that have a long shelf life, such as canned foods.
4. **Correct Response: A.** (SMR Code: 2.1) Ingredients on food labels must be listed for any food product with more than one ingredient, with the ingredient of the largest amount, by weight, in the product being listed first, and the remaining ingredients following in descending order according to weight. The Food and Drug Administration and the U.S. Department of Agriculture regulate what foods must have ingredient lists on their labels as well as what ingredients must be listed.
5. **Correct Response: B.** (SMR Code: 2.1) The sample menu shows that Shula is eating a healthy variety of foods from different food groups. Since she has also combined her diet modification with exercise, it is likely that her portion sizes are not appropriate for promoting weight loss. The *2005 Dietary Guidelines for Americans* recommends that adults who are trying to lose weight decrease their caloric intake and increase their level of physical activity.
6. **Correct Response: B.** (SMR Code: 2.1) Lactose intolerance is the inability to effectively digest lactose, or milk sugar, within the body due to a shortage of the enzyme lactase. Common symptoms of lactose intolerance include bloating, cramps, and diarrhea.
7. **Correct Response: C.** (SMR Code: 2.1) The typical diet of people living in the Mediterranean region in southern Europe is low in saturated fats and meats, and high in monounsaturated and polyunsaturated fats, legumes, grains, and fruits and vegetables. This diet, which also includes moderate amounts of fish, poultry, and wine, is thought to contribute to the region's low incidence of heart disease.
8. **Correct Response: C.** (SMR Code: 2.2) Mercury enters the water from natural sources and as a result of human activities. It settles to the bottom of bodies of water, where it is converted to methylmercury by bacteria. The methylmercury is ingested or absorbed by small aquatic organisms and enters the food chain. It is especially important that children and women of childbearing age limit their intake of certain species of fish (e.g., tuna, swordfish, shark) because of the adverse affects methylmercury has on a developing nervous system.

9. **Correct Response: A.** (SMR Code: 2.2) For an individual whose mobility is dependent upon the use of a wheelchair, the U-shaped kitchen is the best choice among the four layouts given. This arrangement provides adequate space to allow the free movement of a wheelchair. Its work triangle has the shortest overall distance between stations, and the sink is centrally located between the cooking and storage stations. It also offers the greatest amount of continuous counter space.
10. **Correct Response: A.** (SMR Code: 2.2) Reducing a gravy involves applying heat to evaporate water, thereby thickening the gravy. A shallow two-quart saucepan will be wider than a taller two-quart saucepan, and will therefore provide a greater surface area. This will better facilitate evaporation.
11. **Correct Response: B.** (SMR Code: 2.2) Second-degree burns penetrate the dermal layer of skin and are more severe than first-degree burns. Flushing a second-degree burn with cold water will help relieve the pain and gently clean the injury. It will also prevent the skin from becoming further damaged by the heat from the burn and minimize inflammation.
12. **Correct Response: D.** (SMR Code: 2.2) The California Uniform Retail Food Facilities Law was passed in 2000 to improve the safety and handling of food in restaurants and other establishments within the state of California.
13. **Correct Response: C.** (SMR Code: 2.2) Like any component of a meal, the vegetable dish selected should complement or favorably contrast the flavors of the other components. For example, a main course of chicken curry could be favorably contrasted with a vegetable dish that is less spicy, such as a cucumber yogurt salad.
14. **Correct Response: C.** (SMR Code: 2.2) Flour typically settles and becomes compact during transportation and storage. Spooning flour gently into a measuring cup will loosen and aerate the flour. Overfilling the cup and leveling it off with a straightedge will ensure that the measuring cup has been filled to capacity.
15. **Correct Response: D.** (SMR Code: 2.2) Most culinary schools offer two- and/or four-year degree programs in food preparation and restaurant management. A typical educational path for someone wishing to be a head chef involves classroom work, an apprenticeship, and professional work experience. The head chef is responsible for the overall operations of the establishment, while the daily operation of the kitchen is usually the responsibility of the sous-chef.

Examples of Responses to Sample Constructed-Response Questions for CSET: Home Economics Subtest II

Nutrition, Foods, and Hospitality

Question #16 (Strong Response)

Mr. Jenkins may experience an increase in digestive problems as he ages. He also may begin to experience high cholesterol.

To aid his digestion, he should be sure to consume adequate fiber. He can do this by adding more fruits, vegetables, and whole grains to his diet. He should also maintain adequate hydration, drinking six to eight glasses of water each day.

To guard against high cholesterol, he should decrease foods high in saturated fat such as red meat and replace them with alternative protein sources. He should also continue or increase his exercise.

Question #16 (Weak Response)

Mr. Jenkins needs to watch his diet carefully as he gets older. He cannot maintain his health and vigor if he eats only meat and potatoes. He should also avoid sweets and fats. Proper nutrition is just as important for the elderly as it is for children.

If Mr. Jenkins does not know how to cook he could enroll in a local Meals on Wheels program. This would provide him with a healthy meal each day.

If he is able to cook but does not know how to shop for healthy foods, he might be able to get someone to help him shop and plan meals, or enlist the services of a nutritionist.

Question #17 (Strong Response)

This menu is high in fat, protein, and carbohydrates, and low in vitamins, calcium and fiber. It is bland in color with no visual interest, and homogeneous in texture and temperature, consisting of mostly soft foods served hot.

Adding chopped vegetables to the eggs or making vegetable omelets would add vitamins and fiber as well as color and texture. Eliminating either the French toast or the pancakes would reduce the carbohydrates. Adding fresh fruit would provide more visual and textural variety, fiber, and vitamins.

In preparing this meal, the eggs and sausage must be cooked thoroughly to prevent risk of bacterial or parasitic infection. To prevent the growth of bacteria, hot foods must be kept hot and cold foods must be kept cold.

Question #17 (Weak Response)

This is a very hearty brunch menu, including far more items than are needed. For example, why have both pancakes and French toast? Why have both sausage and ham? The number of dishes could be reduced by half and the menu would still be adequate and the brunch would be a great deal easier to prepare.

It is important to be careful in using the stove to avoid getting burned. This is especially true if the cooks are not experienced. This is another reason to have a smaller menu.

Scoring Information for CSET: Home Economics Subtest II

Responses to the multiple-choice questions are scored electronically. Scores are based on the number of questions answered correctly. There is no penalty for guessing.

There are two constructed-response questions in Subtest II of CSET: Home Economics. Each of these constructed-response questions is designed so that a response can be completed within a short amount of time—approximately 10–15 minutes. Responses to the constructed-response questions are scored by qualified California educators using focused holistic scoring. Scorers will judge the overall effectiveness of your responses while focusing on the performance characteristics that have been identified as important for this subtest (see below). Each response will be assigned a score based on an approved scoring scale (see page 14).

Your performance on the subtest will be evaluated against a standard determined by the California Commission on Teacher Credentialing based on professional judgments and recommendations of California educators.

Performance Characteristics for CSET: Home Economics Subtest II

The following performance characteristics will guide the scoring of responses to the constructed-response questions on CSET: Home Economics Subtest II.

PURPOSE	The extent to which the response addresses the constructed-response assignment's charge in relation to relevant CSET subject matter requirements.
SUBJECT MATTER KNOWLEDGE	The application of accurate subject matter knowledge as described in the relevant CSET subject matter requirements.
SUPPORT	The appropriateness and quality of the supporting evidence in relation to relevant CSET subject matter requirements.

Scoring Scale for CSET: Home Economics Subtest II

Scores will be assigned to each response to the constructed-response questions on CSET: Home Economics Subtest II according to the following scoring scale.

SCORE POINT	SCORE POINT DESCRIPTION
<p style="text-align: center;">3</p>	<p>The "3" response reflects a command of the relevant knowledge and skills as defined in the subject matter requirements for CSET: Home Economics.</p> <ul style="list-style-type: none"> • The purpose of the assignment is fully achieved. • There is an accurate application of relevant subject matter knowledge. • There is appropriate and specific relevant supporting evidence.
<p style="text-align: center;">2</p>	<p>The "2" response reflects a general command of the relevant knowledge and skills as defined in the subject matter requirements for CSET: Home Economics.</p> <ul style="list-style-type: none"> • The purpose of the assignment is largely achieved. • There is a largely accurate application of relevant subject matter knowledge. • There is acceptable relevant supporting evidence.
<p style="text-align: center;">1</p>	<p>The "1" response reflects a limited or no command of the relevant knowledge and skills as defined in the subject matter requirements for CSET: Home Economics.</p> <ul style="list-style-type: none"> • The purpose of the assignment is only partially or not achieved. • There is limited or no application of relevant subject matter knowledge. • There is little or no relevant supporting evidence.
<p style="text-align: center;">U</p>	<p>The "U" (Unscorable) is assigned to a response that is unrelated to the assignment, illegible, primarily in a language other than English, or does not contain a sufficient amount of original work to score.</p>
<p style="text-align: center;">B</p>	<p>The "B" (Blank) is assigned to a response that is blank.</p>